



Bedford County

DEPARTMENT OF COMMUNITY DEVELOPMENT

DECK POST/PIER FOOTINGS

Donnie Dillon, Building Official
 122 East Main Street Suite G-03
 Bedford, Va. 24523
 ddillon@bedfordcountyva.gov
 Phone: 540 586-7616
 Fax: 540 586-2059
 www.co.bedford.va.us

Post:

TABLE R507.8
DECK POST HEIGHT* (feet)

DECK POST SIZE	MAXIMUM HEIGHT*
4x4	8
4x6	8
6x6	14

For SI: 1 inch = 25.4 mm, 1 foot = 304.8 mm.
 a. Measured to the underside of the beam.

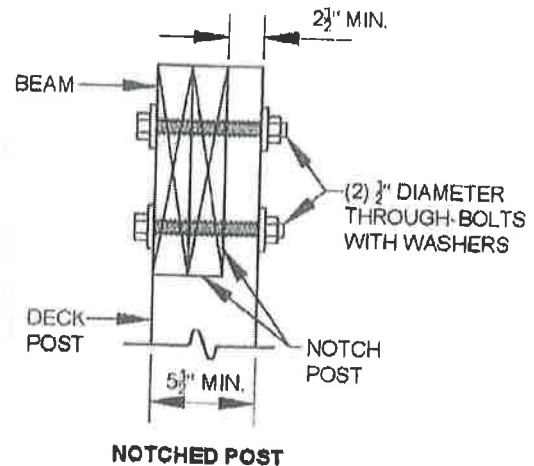

Pier Footings:

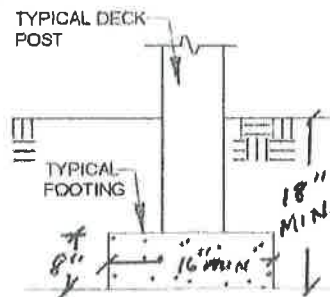

Stairs & Rails:

- A minimum 36" deck or landing is required outside each exterior door.
- Deck or landing must be within 8 1/4" of the top of threshold unless the door swings out.
- Guardrails are required if the deck is over 30" above grade anywhere within 36".
- Guardrails are required to be a minimum of 36" high.
- Guardrails may have no opening greater than 4".
- Guardrails for stairs must be a minimum of 34" above the front edge of the treads.
- Guardrails for stairs may have no opening greater than 4 3/8" including the riser.
- A handrail is required on one side of stairs if there are 4 or more risers.
- Handrails must be between 34" and 38" from the front edge of the treads.
- Stairs must have a minimum 9" tread and maximum 8 1/4" rise.

**THE GENERAL INFORMATION PROVIDED IS BASED ON THE 2012 VIRGINIA RESIDENTIAL CODE
 SUBJECT TO FIELD INSPECTIONS FOR CODE COMPLIANCE**

FOR SPECIFIC CODE QUESTIONS PLEASE CONTACT BUILDING INSPECTIONS AT (540) 586-7616